

POLICY: RACE DAY ORGANISATION & DRAWS

Policy No	027	Issue	13
Date of Board Approval	8 December 2020	Scheduled review date	December 2021

Introduction

The Racing Committee (RC) is given the responsibility each season to coordinate the race program and to seek Board endorsement of it prior to season commencement. The organisation of race days will be allocated to some participating Member Clubs on a rotational basis. The roster will usually be set at the first RC meeting after the State Championships.

Purpose

The purpose of this Policy is to provide direction to the RC and the organising Member Club (Club) to coordinate each race day.

Policy

1. Event Entry Organisation

1. Prior to season commencement each Club will be assigned a race day to coordinate with some smaller Clubs possibly combining to organise.
2. A RC meeting will occur at least 10 days prior to the race day to coordinate the event. The organising Club of the forthcoming race day will chair the RC meeting.
3. At least 11 days before the race day Clubs are required to indicate in the online database (Revolutionise Sport) the races they will be entering. Team entries will close the Friday after the RC meeting (11:45pm).
4. Just prior to the RC meeting or at the meeting, the organising Club is to coordinate the draft race program for review based on the online entries received at that time. This should be an indicative program of the number of races and timing.
5. Clubs will then review this program at the RC meeting and discuss any required changes.
6. The organising Club will circulate the proposed race draw by the Tuesday prior to the Race day along with the task list.
7. Clubs are to each record in Revolutionise Sport the names of their individual paddlers and volunteer/s participating on the respective team sheet. The DBSA Treasurer will invoice Clubs via Revolutionise Sport, based on the Clubs' team sheets.
8. Individual clubs will print out two copies of their team sheets, laminate them and present to the Race Secretariat at least 30 minutes before the start of the first race.
9. Withdrawals and changes after close of business on the Tuesday prior to a weekend event or within five days of other events will incur a charge of \$40 (plus GST).
10. A minimum of three crews are required for an event to be raced unless it is an Open Age event (there is no minimum number for Open Age). If a crew withdraws after final entries have been submitted and it reduces the total entries to two, that event will still be run.
11. The organising Club is to ensure as soon as possible after race completion, that a copy of the race results is emailed to admin@dragonboatsa.com for uploading to the website.

RACE DAY ORGANISATION SCHEDULE – CHECK LIST

11 days prior to event	All Clubs to indicate on Revolutionise by COB the categories they will be entering.
10 days prior to event	Race Committee meeting chaired by Organising Club. Draft program to be discussed and amended.
5 days prior to event	Organising club to circulate proposed Race Draw and task list. Any changes after COB on this day incur a charge of \$40.
1 day prior to event	Clubs to have entered individual paddlers and volunteer name on Revolutionise by this time
1/2 hour before 1st race	Clubs will submit laminated team sheets to Race Secretariat

2. Completing a Race Draw

1. Ensure that the results from the latest previous races for the categories in the draw are available.
2. Rank the crews entered in order of their last finishes – this also applies to the Peter Bristow Long Course Event. The order for the PB race is the slowest off first and the previous year's winner last (at 2 minute intervals).
3. Allocate the crews to lanes as follows:
 - Rank 1 – Lane 3
 - Rank 2 – Lane 4
 - Rank 3 – Lane 2
 - Rank 4 – Lane 5
 - Rank 5 – Lane 1
 - Rank 6 – Lane 6

If using more than 6 lanes the fastest seeded boat is in the middle lane with the second fastest on the left of them third on the right of them – progressing on both sides in that order
4. If there are two (2) or more heats, the lanes are allocated in ranking order to the heats. In a 2 heat category the following lane allocations would apply:
 - Rank 1 – Heat 1 – Lane 3
 - Rank 2 – Heat 2 – Lane 3
 - Rank 3 – Heat 1 – Lane 4
 - Rank 4 – Heat 2 – Lane 4
 - Rank 5 – Heat 1 – Lane 2
 - Rank 6 – Heat 2 – Lane 2
 - Rank 7 – Heat 1 – Lane 5
 - Rank 8 – Heat 2 – Lane 5
 - Rank 9 – Heat 1 – Lane 1
 - Rank 10 – Heat 2 – Lane 1
5. Those crews who are unable to be ranked due to no recent results can be allocated lanes after the ranked crews in the order that it is reasonably assumed that they would finish or on a random draw.
6. The racing sequence for the draw should be as follows:
 - Senior C Mixed
 - Senior B Mixed
 - Senior A Mixed
 - Open Age Mixed
 - Senior C Women
 - Senior C Open
 - Senior B Women
 - Senior B Open



- Senior A Women
 - Senior A Open
 - Open Age Women
 - Open Age Open
 - B Grade to be used through the program (x4 races) to create breaks
7. Should the above categories be changed for a season of racing to those listed below then the sequence for the draw will be as follows:
- 55+ – Mixed
 - 40+ – Mixed
 - Open – Mixed
 - 55+ – Women
 - 55+ – Open
 - 40+ – Women
 - 40+ – Open
 - Open – Women
 - Open – Open
 - B Grade to be used through the program (x4 races) to create breaks

Should the race schedule include 10's and 20's racing then all 10's racing shall be completed before 20's racing can commence.

3. Race Plans

1. IDBF and AusDBF Race Plans

- a) In general DBSA shall follow both the IDBF and AusDBF race plan for season and state Championship racing. Where the number of competitors in a particular racing category is not sufficient to ensure full finals the DBSA Board, in their discretion, may alter the race plan to increase the number of crews in the finals:
- b) As a general rule, the following race plans will be adhered to:



DRAGONBOATS SA

F I E R C E F A S T F U R I O U S

TAIL RACE PLAN

(USING SIX LANES)

PLAN. T1. = 5, 6, 7 or 8 Crews racing

Crews Per Heat	Heat (H) Draw.	L A N E	Repechage (Rp) Draw.	L A N E	Tail Race (TR) Draw.	L A N E	Semi Final (SF) Draw.	L A N E	Grand Final (GF) Draw.	L A N E										
<u>5.</u> H1=3 H2=2	Heat.1 3 1 5	4 3 2	REPECHAGE. 3 in Hs 4 in Hs 5 in Hs (6 in Hs) (7 in Hs) (8 in Hs)	3 4 2	No Ra		NO SEMI FINALS		GRAND Final 1 st in H1 1 st in H2 1 st in Rp (2 nd in Rp) (3 rd in Rp)	3 4 2										
<u>6.</u> H1=3 H2=3	(7)	(5)		(5) (1) (6)						Minor Final (MF) Draw.					(5) (1)					
Heat.2 4 2	4 3	(2)		Minor Final (MF) Draw.																
<u>7.</u> H1=4 H2=3	(6) (8)	(5)																		
<u>8.</u> H1=4 H2=4					3 2 4		3 rd in Rp 4 th in Rp 5 th in Rp	3 4 2	3 4 2											
	Heats: Heat Winners the Grand Final. The Rest to Repechage.		Rep: 5 or 6 crews Winner to GF. 7 crews. First 2 to GF. 8 crews 3 to GF All rest to MF.				Minor Final is to decide 4 th and 5 th or 5 th to 8 th places in the competition		Grand Final is to decide 1 st to 3 rd and 4 th and 5 th places in the competition.											

RACE FORMAT FOR RACES WITH 6 to 8 Crews – Using 6 Lanes

Plan T.1

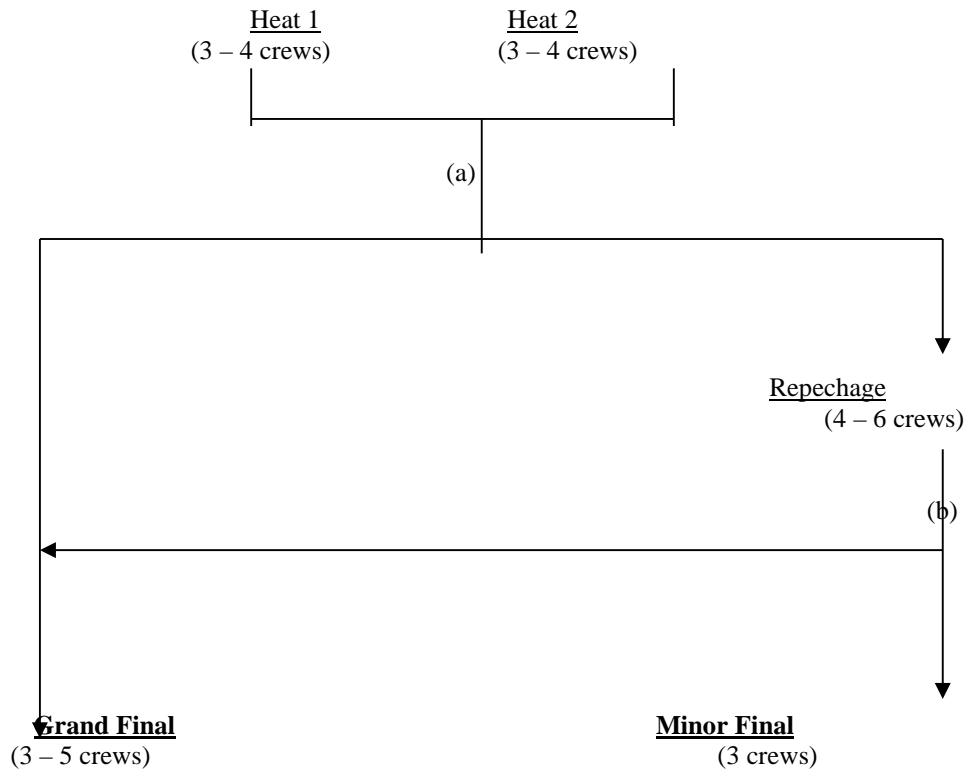

Notes:

- (a) The 1st placed crew in each Heat goes to the Grand Final, the rest to the Repechage.
- (b) For Races with 6 crews the 1st placed crew will go to the Grand Final.
 For Races with 7 crews the 1st and 2nd placed crews will go to the Grand Final.
 For Races with 8 crews the 1st, 2nd and 3rd placed crews will go to the Grand Final
 For all races the remaining crews go to the Minor Final.



TAIL RACE PLAN

(USING SIX LANES)

PLAN. T2. = 9, 10, 11, or 12 Crews

Crews Per Heat	Heat (H) Draw.	L A N E	Repechage (Rp) Draw.	L A N E	Tail Race (TR) Draw.	L A N E	Semi Final (SF) Draw.	L A N E	Grand Final (GF) Draw.	L A N E
9. H1=5 H2=4	Heat.1 7 3	5 4	REPECHAGE . 1 4 in Hs 6 in Hs 8 in Hs (10 in Hs) (12 in Hs)	3 4	No Rac	NO SEMI FINALS			GRAND Final 1 st in H1 1 st in H2 3 rd in Hs 1 st in Rp1 1 st in Rp2 3 rd in Rps	3 4
10. H1=5 H2=5		3 2		2 (5)						2 (1)
11. H1=6 H2=5	Heat.2 8 4	5 4	REPECHAGE . 2 5 in Hs 7 in Hs 12 in Hs 9 in Hs (11 in Hs)	3 4					Minor Final (MF) Draw.	
12. H1=6 H2=6		3 2		2 (1)						2 (1)
									MINOR Final 4 th in Rps 5 th in Rps 6 th in Rps (7 th in Rps) (8 th in Rps) (9 th in Rps)	3 4 2 (5) (1) (6)
	Heats: Winners + Fastest loser overall to GF Rest to Reps.		Reps: Rep Winners + Fastest Loser OA to Grand Final. The Rest to Minor Final				Minor Final is to decide 7 th to 12 th places in the competition		Grand Final is to decide 1 st to 6 th places in the competition.	

Plan Summary: 2 Heats; 2 Reps; 1 Minor Final; 1 Grand Final = Total 6 Races.



RACE FORMAT FOR RACES WITH 9 to 12 Crews – Using 6 Lanes

Plan T.2

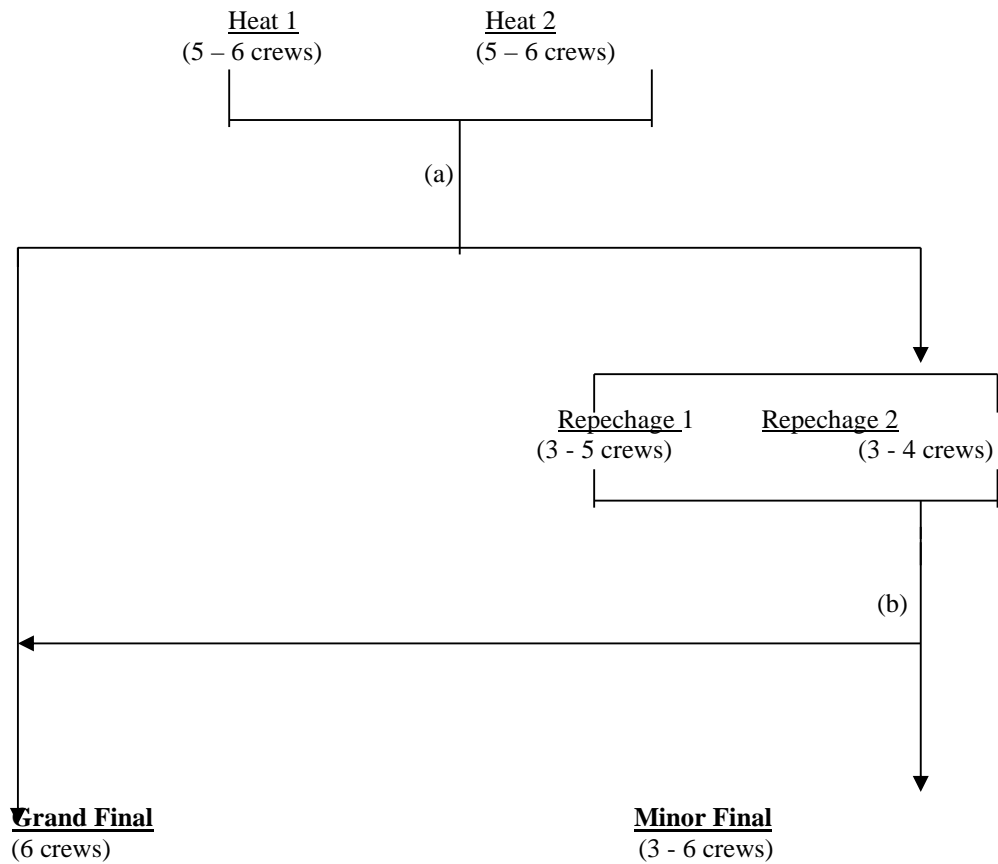

Notes:

- (a) The 1st placed crew in each Heat, plus the fastest loser overall from the Heats, go to the Grand Final, the rest go to the Repechages.
- (b) The 1st placed crew in each Rep, plus the fastest loser overall from the Reps, go to the Grand Final, the remaining crews go to the Minor Final.



4. Best Times Race Plans

In the Race Plans where we score the best two times of three races or the best three times of four races, crews are seeded as in Section 2 and for each subsequent round they are rotated in an equitable manner. (All crews should have an equal share of inside and outside lanes).

It is recommended that for courses which have uneven lanes such as **Torrens Racing** the Best Times Race Plan should be utilised with only the first heat seeded from the previous event and subsequent heats rotate the lanes so that each crew races in at least lanes 2 & 3 once. The best two times out of three races should be used.

B Grade racing should use Best Times Race Plan where they will drop their slowest time and total their remaining times to decide the winner. Generally, they will have four races but this may alter depending on circumstances.

5. Race day Task Lists

1. Race day task lists have been produced for each venue and can be downloaded from the DBSA website – www.dragonboatsa.com.
2. These task lists should be reviewed by all Clubs as soon as they are aware of their allocated event.
3. Some items can be actioned well in advance and can save a deal of anxiety later.
4. When allocating race day duties to clubs it is advisable to review previous task lists and share the tasks evenly to all clubs.